



Operator's Manual
GASOLINE POWERED EARTH AUGER
43cc, 2-CYCLE
with 8" Auger Bit

MODEL Nos. PEA438

For Occasional Use Only

Look inside for:

	Page
Safety Definitions	1
Important Safety Information	2-4
Product Specifications	5
Parts & Features	5
Assembly	5-6
Operation	6-8
Routine Maintenance	9-10
Troubleshooting	11
Technical Service	11
Warranty	12-17



IMPORTANT:

Thank you for purchasing this Powermate® Earth Auger. This manual provides complete instructions for safely operating, and maintaining your Earth Auger. Read and save these instructions. Refer to this manual each time before using your Earth Auger.

Record the following for future reference:

Mfg. Date Code : _____

Date of Purchase: Attach a copy of your sales receipt.

Consumer Toll Free Number: 1-800-737-2112

Refer to the website for electronic manual and parts book.

www.powermate.com

▲ WARNING CALIFORNIA PROPOSITION 65 WARNING

Engine exhaust, some of its constituents, and certain product components contain or emit chemicals known to the State of California to cause cancer and birth defects or other reproductive harm.



If you have a question or problem...

CALL TOLL FREE: 1-800-737-2112

KEEP THIS MANUAL FOR FUTURE REFERENCE





Safety Definitions

• Save all instructions



Safety Warning Symbols:

	<p>Indicates Warning.</p>		<p>Extremely hot surface. Do not touch a hot muffler, gear box or cylinder, you may get burned. These parts get extremely hot from operation and remain hot for a short time after the unit is turned off.</p>
	<p>Read these instructions carefully.</p>		

Control and Operating Symbols:

	<p>Choke Control: Cold Start Run/Warm Start</p>		<p>Fuel Mixture: 40:1 (Unleaded Gas : 2 Cycle Oil)</p>
	<p>Fuel Primer: Press 6 times.</p>		<p>Ignition Switch: ON OFF</p>

The information listed below should be read and understood by the operator. We utilize the symbols below to allow the reader to recognize important information about their safety.

	<p>Indicates an imminently hazardous situation which, if not avoided, will result in death or serious injury.</p>
	<p>Indicates a potentially hazardous situation which, if not avoided, could result in death or serious injury.</p>
	<p>Indicates a potentially hazardous situation which, if not avoided, may result in minor or moderate injury or equipment/property damage.</p>

Important Safety Information

- Save all instructions

READ AND UNDERSTAND ALL INSTRUCTIONS BEFORE OPERATING EARTH AUGER.

Before Operating Earth Auger

▲ DANGER

1. Contact your local utility company in order to locate underground electrical lines or pipes prior to using this product. Failure to do so may result in serious injury or death and possible damage to equipment or property.
2. The auger engine exhaust contains carbon monoxide, an odorless and potentially deadly gas. Never start or run the auger inside an enclosed area or building. Breathing exhaust fumes can kill.

▲ WARNING

Read and follow all warnings and safety instructions. Failure to do so can result in serious injury to you or bystanders.

1. Avoid Dangerous Environments
 - a. Do not operate Earth Auger while under the influence of alcohol, medications, or drugs.
 - b. Do not operate Earth Auger when you are tired.
 - c. Do not use this Earth Auger if you are mentally or physically unable to operate safely.
2. Inspect Earth Auger for damaged parts, and make sure all fasteners and guards are in place and secure. Replace any damaged parts.
3. The handles must be mounted in accordance with the Operators Manual.
4. Never use this Earth Auger with other accessories not specifically designed for use with this product.
5. Dress properly when operating Earth Auger.
 - a. Always wear heavy long pants, boots, gloves, and a long-sleeve shirt.
 - b. Do not wear loose clothing or jewelry that can get caught in the moving parts of the Earth Auger.
 - c. Always wear protective hair covering to contain long hair.
6. Always wear a face or dust mask if operation is dusty.
7. Always wear eye protection that meets or exceeds the requirements of ANSI Z87.1.
8. Always wear hearing protection, which meets or exceeds ANSI standards.
9. Thoroughly inspect the area where the Earth Auger is to be used and remove all foreign objects.
10. Auger blades and drilling points are sharp. Avoid contact with the auger blades and drilling points while installing auger bit, starting or transporting the unit.

While Operating Earth Auger

▲ CAUTION

Prolonged exposure to vibrations through use of gasoline powered hand tools could cause blood vessel or nerve damage in fingers, hands, and joints of people prone to circulation disorders or abnormal swellings. Extensive use in cold weather has been linked to blood vessel damage in otherwise healthy people. If symptoms occur such as numbness, pain, loss of strength, change in skin color or texture, or loss of feeling in the fingers, hands, or joints, discontinue the use of this tool and seek medical attention.

▲ WARNING

1. Maintain a firm grip on the handles with both hands while using the auger. Keep the auger bit away from your body and below waist level.
2. Stay alert. Use common sense. Watch what you are doing.
3. Do not operate Earth Auger if it is damaged or not securely and fully assembled.
4. Only well instructed adults should operate Earth Auger. Never allow children to operate Earth Auger.

Important Safety Information (Continued)

• Save all instructions

While Operating Earth Auger

5. Keep children away. Keep all bystanders at least 50 ft (15 m) away.
6. This Auger is only intended for earth digging. Do not use Earth Auger for any job except that for which it is intended. Severe personal injury to yourself or others can result.
7. The Auger Bit should not rotate while engine is idling. If it does rotate when engine is idling, contact technical service immediately for instructions.
8. Maintain your balance and proper footing at all times. Do not overreach.
9. Keep all parts of your body away from cutting area, the rotating auger bit and blades, and hot surfaces.
10. Always keep the throttle control on your right hand side, while the exhaust points away from your body.
11. Use extreme caution when using this unit. Bit thrust or Kick Back may occur when the spinning blade contacts an object that it does not immediately cut. A Kick Back can be violent enough to cause the unit and/or operator to be propelled in any direction, and possibly lose control of the unit. Kick Back can occur without warning if the bit snags, stalls or binds.
12. An improper or dull bit blade can cause serious personal injury. Bit blades must be sharp. Discard earth bit blades that are bent, warped, cracked, broken or damaged in any way.
13. Use only the manufacturer's replacement bit blade intended for this unit. Do not use any other bit blade. To install any other brand bit blade to this unit can result in serious personal injury.
14. Do not force the earth auger. It will do the job better and with less likelihood of a risk of injury when used at the rate for which it was designed.
15. After turning the unit off, make sure the earth auger bit has stopped before the unit is sat down.
16. A coasting bit can cause injury while it continues to spin after the engine is stopped or throttle lever is released. Maintain proper control until the bit has completely stopped rotating.
17. Never touch the area near the muffler because it is extremely hot and can cause severe burns. Never touch parts of the engine that become hot after operation.

Fuel Safety

WARNING

1. Mix and pour fuel outdoors WHERE THERE ARE NO SPARKS OR FLAMES.
2. Never fill gasoline container or the product's fuel tank inside a vehicle or in a truck bed. Accidental electrical static discharge can ignite fuel vapors which could result in serious injury or death.
3. Use a container approved for gasoline.
4. Do not smoke or allow smoking near fuel or the unit.
5. Avoid spilling fuel or oil. Wipe up all fuel spills.
6. Move at least 10 feet (3 meters) away from fueling site before starting engine.
7. Stop engine and allow to cool before removing fuel cap. Remove fuel cap slowly.
8. Store unit and fuel in area where fuel vapors cannot reach sparks or open flames from water heaters, electric motors or switches, furnaces, ect..

Important Safety Information (Continued)

- Save all instructions

Maintenance, Transporting & Storage of Earth Auger

1. Disconnect the spark plug before performing maintenance. Secure spark plug boot away from engine and frame to prevent arcing.
2. Maintain Earth Auger with care. Inspect unit periodically. If unit is not working properly or damaged, have it repaired by a qualified service center.
3. Check for misalignment of moving parts, binding of moving parts, broken parts, mounting, and any other condition that may affect its operation.
4. Any part that is damaged should be properly repaired or replaced by a qualified service center.
5. Use only genuine Powermate® replacement parts and accessories. Use of any non-Powermate® parts or accessories could lead to injury, damage to the unit, and will void your warranty.
6. Do not remove or modify any parts. Removing or modifying parts could lead to injury, damage the Earth Auger and will void the warranty.
7. Keep handles dry, clean, and free from oil and grease.
8. Allow engine to cool and empty the fuel tank into an approved container before storing or transporting in vehicle. Use up remaining fuel in the carburetor by starting the engine and letting it run until it stops.
9. When not in use, store unit indoors in a dry location. Store Earth Auger above the reach of children or in a locked area out of the reach of children.
10. For cold weather operation, store the unit in a cool environment to minimize the possibility of condensation which could lead to unsatisfactory product performance.
11. When preparing the Earth Auger for storage or when Earth Auger will not be used for 30 days or more:
 - a. Inspect and clean the Earth Auger thoroughly.
 - b. Lightly oil all external metal surfaces.
 - c. Remove the spark plug, place a few drops of 2-cycle engine oil into the cylinder. Pull the recoil starter several times to distribute the oil. Replace the spark plug.
 - d. Inspect and clean air filter as required.

NOTE: To prevent fuel gum deposits in the carburetor and fuel system, it is acceptable to use fuel stabilizer. Follow the stabilizer manufacturer's instructions. Run the engine at least 5 minutes after adding stabilizer.

WARNING

Store unit and fuel in area where fuel vapors cannot reach sparks or open flames from water heaters, electric motors or switches, furnaces, etc.

Product Specifications

• Save all instructions

Engine	43cc, 2 cycle	Spark Plug	NGK - BPMR7A
Fuel Tank Capacity	40.6 oz (1.2 L)	CHAMPION - CJ7Y
Fuel Type	Unleaded Gasoline – 87 Octane or higher	TORCH L7RTC
Auger Bit	8"or equivalent
2-Cycle Oil Type	2-Cycle Oil that meets or exceeds	Net Weight	43cc Auger Powerhead - 22 lbs
.....	JASO – FC Specifications	8" Auger Bit - 13 lbs
Fuel Mixture	40:1 (Gasoline: 2-Cycle Oil)		

Parts & Features

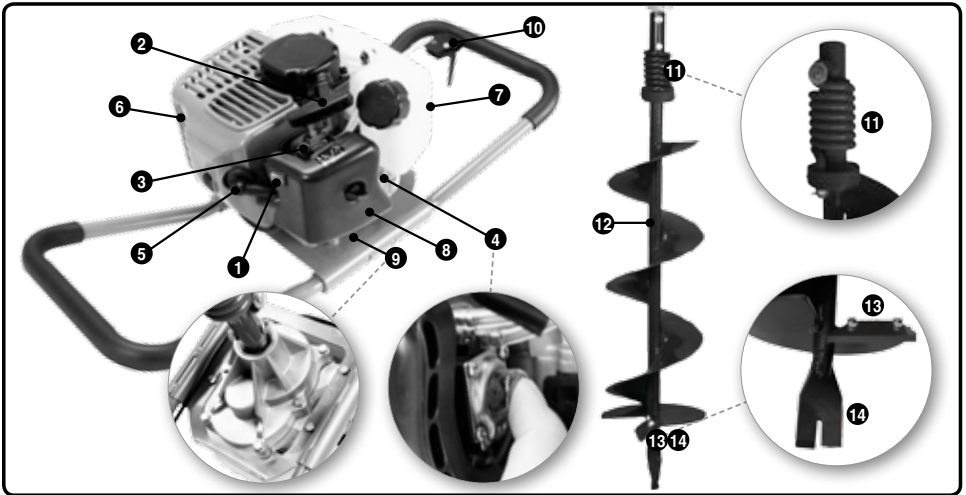

POWERHEAD:		8" AUGER BIT:	
1.	On/Off Ignition Switch	6.	Muffler
2.	Recoil Starter Handle	7.	Fuel Tank
3.	Choke Lever	8.	Air Filter Cover
4.	Fuel Primer Bulb	9.	Gear Box
5.	Spark Plug	10.	Throttle Lever
		11.	Adapter
		12.	8" Auger Body
		13.	Earth Blade (replaceable)
		14.	Fishtail Point (replaceable)

Assembly

 If you need assistance or find any parts missing, CALL TOLL FREE: 1-800-737-2112

Parts Included With The Earth Auger

- | | |
|--------------------------------|------------------------------|
| 1. 43cc Auger Powerhead | 5. 10mm Wrench |
| 2. 8" Auger Bit | 6. 12mm Wrench |
| 3. Fishtail Point | 7. Spark Plug Wrench |
| 4. M8-1.25 x 45 Bolt & Locknut | 8. 2-Cycle Engine Oil Bottle |

▲ WARNING

Do not operate Earth Auger if it is damaged or not securely and fully assembled.

Tools Needed For Assembly

- Adjustable wrench.

Assembly (Continued)

• Save all instructions

A To Assemble Auger Bit

1. Insert the spark plug wrench handle into the cross hole in the adapter.
2. Hand tighten the Fishtail Point into the opposite end of the adaptor. Avoid contact with the Earth Blade and cutting edge of the Fishtail Point.
3. Grip the side of the Fishtail Point with an adjustable wrench and tighten while holding the spark plug wrench to secure the auger bit from rotating.

B To Assemble Auger Bit to Powerhead



1. Move the On/Off Switch to the off position.
2. Remove the Spark Plug boot from the Spark Plug and secure the boot away from the engine and frame.
3. Insert the Powerhead output shaft into the auger bit adapter and align the top hole of the auger bit to the hole at the output shaft.
4. Insert the bolt with concave washer installed (concave side towards adapter) thru the hole in the Adapter and Powerhead shaft.
5. Install second concave washer and locknut and tighten with 13mm wrenches provided.
6. Reinstall the Spark Plug boot onto the Spark Plug.

Operation

• Save all instructions

A Before Starting Engine:

Mixing Gasoline / 2-Cycle Oil

▲ WARNING

Do not smoke or allow smoking near fuel or the Earth Auger. Mix and pour fuel outdoors WHERE THERE ARE NO SPARKS OR FLAMES.

The 2-cycle engine on your unit requires that gasoline and 2-cycle engine oil be pre-mixed before adding to the unit's fuel tank. To mix the gasoline/2-cycle oil:

1. Use FRESH unleaded gasoline with an octane rating of 87 or higher. Do not use gasoline containing more than 10% ethanol.

▲ CAUTION

Use of gasoline containing more than 10% ethanol can damage the engine.

2. Always use 2-cycle oil that meets or exceeds JASO – FC specifications and is intended for mixing at a gasoline/oil ratio of 40:1.
3. Do not use automotive or 2-cycle marine outboard oil. These will damage your unit's engine and void the warranty.
4. Always mix the gasoline and 2-cycle oil in a container approved for gasoline. Never mix fuel directly in the unit's fuel tank.

5. Follow instructions on 2-cycle oil container for mixing fuel. Mix gasoline and 2-cycle oil at a ratio of 40:1. A mixture with a 40:1 ratio is obtained by mixing 1 gallon (3.8 liters) of gasoline with 3.2 ounces of oil (95 ml). After adding oil to gasoline, shake container momentarily to ensure proper mixing.

6. Mix only enough fuel for your immediate needs. Do not store pre-mixed fuel.
7. Stop engine and allow to cool before refueling.
8. To fill the unit's fuel tank with the gasoline/oil mixture, place the Powerhead upright on the ground or on a sturdy bench and wipe and any debris from around the fuel cap.
9. Remove fuel cap slowly and use a funnel to pour the mixture into the tank, and replace the fuel cap.
10. Avoid spilling fuel or oil. Wipe up all fuel spills.
11. Move at least 10 feet (3 meters) away from fueling site before starting engine.

Operation (Continued)

- Save all instructions

B Starting Engine:

▲ WARNING

1. Ensure that the four handle retaining pins are fully engaged into the Powerhead frame and that the handle bars are secure to the Powerhead frame.
2. Check that all guards and fasteners are in place and secure.
3. Keep all parts from your body and clothing away from drilling location, Auger Bit and Powerhead
4. Ensure that no grass or other debris is wrapped around any part of the Auger Bit, Powerhead or handles.
5. The Powerhead can cause a sudden jerk on the Recoil Starter Handle due to the engine compression and ignition. Maintain a firm grip on the Powerhead handle and Recoil Starter Handle and follow the instruction below to avoid injury.
6. Ensure that the unit is in a stable and controllable position before pulling the Recoil Starter Handle. When the unit starts, raise the unit to a vertical position and maintain control of the unit with both hands on the handle bars and the Muffler exhaust port facing away from your body before engaging the Throttle Lever.
7. Never leave the auger running while unattended.
8. Never carry the unit between drilling locations while engine is running.

Starting Position

1. Place the right handle bar flat on the ground and the left handle bar and throttle in the upward position (see Figure 2).
2. While standing on the operating side of the unit place your right foot onto the right handle bar and grip the left handle bar with your left hand. The Auger Bit will be pointing to your left.
3. Tilt the auger to the right so that the Auger Bit is off the ground.
4. See Cold, Warm, or Flooded Engine Starting procedures below.
5. When the engine starts, raise the unit upright and with the auger bit vertical and above the location of operation for drilling.

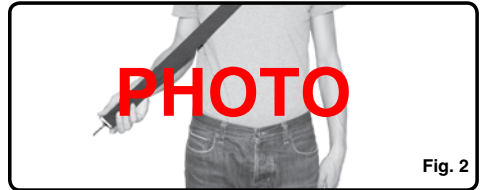

6. Maintain a firm grip with both hands on the handle bars and with the exhaust port facing away from your body before engaging the throttle

▲ WARNING

Keep all parts of your body away from cutting area, the rotating Earth Auger bit and blades, and hot surfaces.

Cold Starting The Engine

DO NOT squeeze the throttle lever until engine starts and runs.

1. Place the unit on a flat surface.
2. Move the On/Off Ignition Switch to the "ON" position (see Fig. 3).
3. Move the Choke Lever to the "COLD START" position (see Fig. 4).
4. Press the Primer Bulb slowly 6 times (see Fig. 5).

NOTE: Follow the instruction in the Starting Position section above for the safe auger position during and after starting the engine.

5. Pull the Recoil Starter Handle sharply until the engine starts and runs.
6. After engine starts and runs for 10-15 seconds, move choke lever to "Run/Warm Start" position (see Figure 4).

Note: When the weather gets cold, please allow the engine to warm up at idle for longer period of time, before moving the Choke Lever to RUN/WARM START position.

Warm Starting The Engine

1. Place the unit on a flat surface.
2. Move the On/Off Ignition Switch to the "ON" position (see Fig. 3).

NOTE: Follow the instruction in the Starting Position section above for the safe auger position during and after starting the engine.

3. With the Choke Lever in "Run/Warm Start" position, use right hand to engage the Throttle Lever, pull the Recoil Starter Handle sharply until the engine starts and runs.

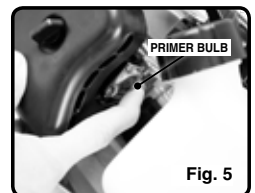
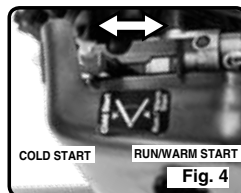
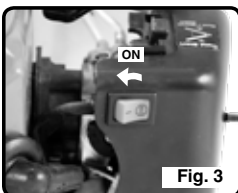

Operation (Continued)

• Save all instructions

Starting A Flooded Engine

1. Place the unit on a flat surface.
2. Move the On/Off Ignition Switch to the "ON" position.
NOTE: Follow the instruction in the Starting Position section above for the safe auger position during and after starting the engine.
3. With the Choke Lever in "Run/Warm Start" position, use right foot to hold the Throttle Lever fully depressed and pull

the starter handle repeatedly until engine starts and runs. This could require pulling the starter handle many times, depending on how badly the unit is flooded.

4. If the engine fails to start, replace the spark plug with a new clean and dry spark plug.
5. Repeat steps 1-3.

If the unit still doesn't start, refer to the **TROUBLESHOOTING** section of this manual or:



If you need assistance or have any questions, **CALL TOLL FREE: 1-800-737-2112**

C Stopping The Auger:

▲ CAUTION

The Auger Bit will continue to rotate for a few seconds after the engine has stopped.

1. Release the Throttle Lever and allow the engine to idle for a few moments.
2. Move the On/Off Ignition Switch to the "OFF" position.

D Engine Break-in Period:

During the first ten (10) hours of use, use the slowest engine speed which allows for effective drilling and avoid operation at high engine speeds for extended periods of time.

This will maximize the life and performance of engine of your unit. Maximum power will be achieved after the first ten (10) hours of engine operation.

E Operating the Earth Auger:

▲ WARNING

While drilling holes, do not force body weight to auger powerhead. Maintain a firm grip on the handles and maintain solid footing.

1. Start the engine following the Starting Engine procedures.
2. Place the tip of the Auger Bit at desired location and hold the unit in the vertical position.
3. Engage the throttle lever, and first start digging a hole at a low speed.
4. Gradually increase the speed as the Auger Bit enters into the soil.

▲ CAUTION

If the Auger Bit will not turn in a hole, turn engine off and remove Auger Bit from the hole. Check Auger Bit for damage and remove any debris from Auger Bit or hole. Secure Spark Plug boot away from the engine and frame to alleviate potential arcing.

Routine Maintenance

- Save all instructions

⚠ WARNING

Disconnect the spark plug before performing maintenance.

A Air Filter:

Accumulated debris and dust in the Air Filter will reduce engine performance, increase fuel consumption and increases the risk of engine damage. Clean the air filter every 5 hours of operation or more frequently in dusty applications.

1. Before removing Air Filter Cover, brush away any loose dirt or debris on and around the filter cover.
2. To remove Air Filter Cover, unscrew the retaining knob and carefully pull the cover out (see Figure 6).
3. Remove and clean foam filter.
 - Light surface dust can readily be removed by tapping the filter.
 - Heavy deposits should be washed out in soap and water. Squeeze out any remaining water and allow the filter to completely dry.
4. Add a teaspoon of thin oil to the filter squeeze out any excess oil.
5. Ensure that the On/Off Switch wire terminals are secure and reinstall the Air Filter Cover.



Fig. 6

⚠ WARNING

Never clean filter in gasoline or other flammable solvents.

B Spark Plug:

Inspect the Spark Plug after every 10-15 hours of use; adjust Spark Plug gap and replace Spark Plug as necessary. Replace Spark Plug every year to maintain engine performance and easy starting.

To inspect or replace the Spark Plug:

1. Remove the insulated Spark Plug boot.
2. Use the Spark Plug wrench to remove the Spark Plug by turning counter-clockwise.
3. Clean and adjust the Spark Plug gap to 0.024 – 0.028 in. (0.6 - 0.7mm).
4. Replace any worn Spark Plug with a recommended replacement (see **PRODUCT SPECIFICATIONS**).
5. Apply anti-seize compound to the Spark Plug threads only following the manufacturer's instructions.
6. Install the Spark Plug finger tight in the cylinder head, then tighten with the Spark Plug wrench. Do not over tighten to 10 to 12 ft-lbs.
7. Replace the insulated Spark Plug boot.

Routine Maintenance (Continued)

• Save all instructions

C Earth Blade and Fishtail Point:

⚠ WARNING

1. Use only the manufacturer's replacement part intended for this Auger Bit. Do not use any other Earth Blade or Fishtail Point. To install any other brand part to this Auger Bit can result in serious personal injury. Replace worn or damaged Earth Blade or Fishtail Point.
 2. Auger blades and drilling points are sharp. Avoid contact with the auger blades and drilling points while replacing or sharpening and while installing auger bit, starting or transporting the unit.
1. Remove the mounting hardware (bolts and nuts), and take off the earth blade (see Figure 7).
 2. Install new Earth Blade with new mounting hardware.
 3. Tighten the bolts to secure blade.
 4. To Replace the Fishtail Point, unscrew the point using an adjustable wrench to grip the side of the Fishtail Point. Replace with new part (see Figure 8).

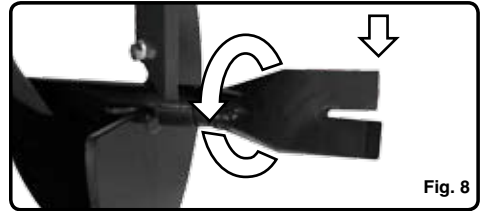
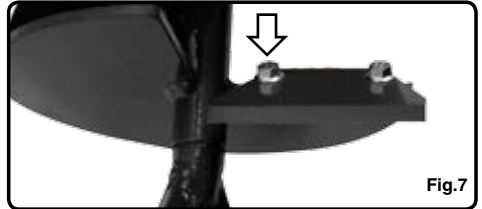

Troubleshooting

• Save all instructions

PROBLEM	POSSIBLE CAUSE(S)	SOLUTION(S)
Engine will not start.	<ol style="list-style-type: none"> 1. Ignition Switch in the "OFF" position. 2. Engine flooded. 3. Fuel Tank empty. 4. Spark Plug not firing. 5. Fuel not reaching carburetor. 6. Carburetor requires adjustment. 	<ol style="list-style-type: none"> 1. Move Ignition Switch to the ON position. 2. See Starting A Flooded Engine in OPERATION section. 3. Fill tank with correct fuel mixture. 4. Replace Spark Plug. 5. Check for kinked or split fuel line; repair or replace. 6. Call toll free phone number below for technical assistance.
Engine will not accelerate, lacks power or stalls.	<ol style="list-style-type: none"> 1. Choke on. 2. Air filter dirty. 3. Spark Plug fouled. 4. Carburetor requires adjustment. 5. Carbon build-up on Muffler outlet screen. 6. Compression low. 	<ol style="list-style-type: none"> 1. Move Choke Lever to "Run/Warm Start" position to turn off choke. 2. Clean air filter. 3. Clean or replace Spark Plug 4. Call toll free phone number below for technical assistance. 5. Call toll free phone number below for technical assistance. 6. Call toll free phone number below for technical assistance.
Engine smokes excessively.	<ol style="list-style-type: none"> 1. Fuel mixture incorrect. 2. Air filter dirty. 3. Carburetor requires adjustment. 	<ol style="list-style-type: none"> 1. Empty Fuel Tank and refill with correct fuel mixture. 2. Clean or replace air filter. 3. Call toll free phone number below for technical assistance.
Engine runs hot.	<ol style="list-style-type: none"> 1. Fuel mixture incorrect. 2. Spark Plug incorrect. 3. Carburetor requires adjustment. 4. Carbon build-up on muffler outlet screen. 	<ol style="list-style-type: none"> 1. See Mixing Gasoline / 2-Cycle Oil in OPERATION section. 2. Replace with correct Spark Plug. 3. Call toll free phone number below for technical assistance. 4. Call toll free phone number below for technical assistance.
Engine will not idle properly.	<ol style="list-style-type: none"> 1. Carburetor requires adjustment. 2. Crankshaft seals worn. 3. Compression low. 	<ol style="list-style-type: none"> 1. Call toll free phone number below for technical assistance. 2. Call toll free phone number below for technical assistance. 3. Call toll free phone number below for technical assistance.
Auger bit turns while engine is idle	<ol style="list-style-type: none"> 1. Idle speed too high. Carburetor requires adjustment. 	<ol style="list-style-type: none"> 1. Call toll free phone number below for technical assistance.
Auger bit jumps or drills slowly.	<ol style="list-style-type: none"> 1. Worn Earth Blade or Fishtail Point. 	<ol style="list-style-type: none"> 1. Replace it with corrected part from manufacturer.

Technical Service

You may have further questions about assembling, operating, or maintaining this Earth Auger. If so, you can contact our Technical Service Department at 1-800-737-2112 (English only).

You may also write to:

METL Corporate Office - CORRESPONDENCE ONLY
ATTN: Technical Service – METL
6700 Wildlife Way
Long Grove, IL 60047

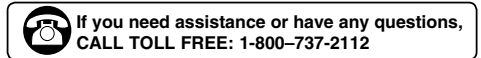

When contacting the Technical Service Department, have ready:

- Your Name
- Your Address
- Your Phone Number

- Model Number of Product
- Date of Purchase (include copy of receipt for written requests)

Warranty

• Save all instructions

A Powermate® Earth Auger Limited Warranty

Always specify model number when contacting the factory.

We reserve the right to amend these specifications at any time without notice. The only warranty applicable is our standard written warranty. We make no other warranty, expressed or implied. **MAT Engine Technologies, LLC** warrants this unit and any parts thereof, to be free from defects in material and workmanship for two years (90 days for reconditioned unit) from the date of first purchase from an authorized dealer, provided that the product has been properly maintained and operated in accordance with all applicable instructions. This warranty is extended only to the original retail purchaser. The bill of sales or proof of purchase must be presented at the time a claim is made under this warranty. This warranty does not cover commercial, industrial, or rental usage, nor does it apply to parts that are not in original condition because of normal wear and tear, or parts that fail or become damaged as a result of misuse, accident, lack of proper maintenance, tampering, or alteration. Travel, handling, transportation, and incidental costs associated with warranty repairs are not reimbursable under this warranty and are the responsibility of the owner. To the full extent allowed by the law of the jurisdiction that governs the sale of the product, this express warranty excludes any and all other expressed warranties and limits the duration of any and all implied warranties, including warranties of merchantability and fitness for a particular purpose to two years from the date of first purchase, and **MAT Engine Technologies, LLC's** liability is hereby limited to the purchase price of the product and **MAT Engine Technologies, LLC** shall not be liable for any other damages whatsoever including indirect, incidental, or consequential damages. Some states do not allow limitation of how long an implied warranty lasts or an exclusion or limitation of incidental or consequential damages, so the above limitation of damages may not apply to you. This warranty provides the original purchaser with specific rights.

For information regarding those rights, please consult the applicable state laws.

METL Corporate Office - CORRESPONDENCE ONLY
ATTN: Technical Service – METL
6700 Wildlife Way
Long Grove, IL 60047

B Federal and California Emissions Control Warranty Statement

This **MAT Engine Technologies, LLC (METL)** outdoor power equipment engine complies with the emissions regulations of:

Powermate® Model No.	Regulatory Agency
PEA438	United States Environmental Protection Agency ("U.S. EPA"), State of California

To the extent there is any conflict between this Emissions Control Warranty and the **METL** Limited Warranty, this Emissions Control Warranty shall apply except where the **METL** Limited Warranty may provide a longer warranty period.

Please read your warranty rights and obligations carefully. Some sections of the warranty may not apply to the specific model you purchased. Unless specifically noted otherwise, the terms below shall apply to all Powermate® products covered within this manual.

YOUR WARRANTY RIGHTS AND OBLIGATIONS

State of California:

The California Air Resources Board and **MAT Engine Technologies, LLC (METL)** are pleased to explain the emissions control system warranty on your 2010 small off-road engine (SORE). In California, new SOREs must be designed, built and equipped to meet the State's stringent anti-smog standards. **METL** must warrant the emissions control system on your SOREs for the periods of time listed below provided there has been no abuse, neglect or improper maintenance of your SOREs.

Warranty (Continued)

- Save all instructions

Other U.S. States / Territories:

In other areas of the United States, your outdoor power equipment engine must be designed, built and equipped so as to conform at the time of sale to U.S. EPA emissions standards for small off-road spark ignition engines at or below 19 kilowatts.

All of the United States:

Your emission control system may include parts such as the carburetor or fuel-injection system, fuel lines, the ignition system, and catalytic converter. Also included may be hoses, belts, clamps, connectors and other emission-related assemblies.

Where a warrantable condition exists, **METL** will repair your small off-road engine at no cost to you including diagnosis, parts and labor.

Manufacturer's Warranty Coverage:

The emissions control system is warranted for two years. If any emissions-related part on your engine is defective, the part will be repaired or replaced by **METL**.

Owner's Warranty Responsibilities:

- As the SORE owner, you are responsible for the performance of the required maintenance listed in your owner's manual. **METL** recommends that you retain all receipts covering maintenance on your SORE, but **METL** can not deny warranty solely for the lack of receipts or for your failure to ensure the performance of all scheduled maintenance.
- As the SORE owner, you should however be aware that **METL** may deny your warranty coverage if your SORE or a part has failed due to abuse, neglect, improper maintenance or unapproved modifications.
- You are responsible for presenting your SORE to a distribution center or service center authorized by **METL** as soon as the problem exists. The warranty repairs should be completed in a reasonable amount of time, not to exceed 30 days.

If you have any questions regarding your warranty coverage, you should contact METL customer service:



If you need assistance or have any questions,
CALL TOLL FREE: 1-800-737-2112

Warranty (Continued)

• Save all instructions

Defects Warranty Coverage:

METL warrants to the original purchaser and each subsequent purchaser that the small off-road engine (SORE) (1) has been designed, built and equipped so as to conform with all applicable regulations; and (2) is free from defects in materials and workmanship that cause the failure of a warranted part to conform with those regulations as may be applicable to the terms and conditions stated below.

- (a) The warranty period begins on the date the engine is first purchased. The warranty period is two years.
- (b) Subject to certain conditions and exclusions as stated below, the warranty on emissions related parts is as follows:
- (1) Any warranted part that is not scheduled for replacement as required maintenance in your **Operator's Manual** is warranted for the warranty period stated above. If the part fails during the period of warranty coverage, the part will be repaired or replaced by **METL** according to Subsection (4) below. Any such part repaired or replaced under warranty will be warranted for the remainder of the period.
 - (2) Any warranted part that is scheduled only for regular inspection in your **Operator's Manual** is warranted for the warranty period stated above. Any such part repaired or replaced under warranty will be warranted for the remaining warranty period.
 - (3) Any warranted part that is scheduled for replacement as required maintenance in your **Operator's Manual** is warranted for the period of time before the first scheduled replacement date for that part. If the part fails before the first scheduled replacement, the part will be repaired or replaced by **METL** according to Subsection (4) below. Any such part repaired or replaced under warranty will be warranted for the remainder of the period prior to the first scheduled replacement point for the part.
 - (4) Repair or replacement of any warranted part under the warranty provisions herein must be performed at a warranty station at no charge to the owner.
 - (5) Notwithstanding the provisions herein, warranty services or repair will be provided at all of our distribution centers that are franchised to service the subject engines.
 - (6) The engine owner must not be charged for diagnostic labor that leads to the determination that a warranted part is in fact defective, provided that such diagnostic work is performed at a warranty station.
 - (7) **METL** is liable for damages to other engine components proximately caused by a failure under warranty of any warranted part.
 - (8) Throughout the engine warranty period stated above, **METL** will maintain a supply of warranted parts sufficient to meet the expected demand for such parts.
 - (9) Any replacement part may be used in the performance of any warranty maintenance or repairs and must be provided without charge to the owner. Such use will not reduce the warranty obligations of **METL**.
 - (10) Add-on or modified parts that are not exempted by the Air Resources Board may not be used. The use of any non-exempted add-on or modified parts by the original or subsequent purchaser will be grounds for disallowing a warranty claims. **METL** will not be liable to warrant failures of warranted parts caused by the use of a non-exempted add-on or modified part.
 - (11) The manufacturer issuing the warranty shall provide any documents that describe that warranty procedures or policies within five working days or requested by the Air Resources Board.

Warranty (Continued)

- Save all instructions

Emission Warranty Parts List*:

The repair or replacement of any warranted part otherwise eligible for warranty coverage may be excluded from such warranty coverage if **METL** demonstrates that the engine has been abused, neglected, or improperly maintained, and that such abuse, neglect, or improper maintenance was the direct cause of the need for repair or replacement of the part. That notwithstanding, any adjustment of a component that has a factory installed, and properly operating, adjustment limiting device is still eligible for warranty coverage. The following emissions warranty parts list is covered.

(1) Fuel Metering System:

- (a) Gasoline carburetor assembly and its internal components (if so equipped)
- (b) Fuel filter (if so equipped)
- (c) Carburetor gaskets
- (d) Fuel pump (if so equipped)

(2) Air Induction System including:

- (a) Intake pipe/manifold
- (b) Air cleaner

(3) Ignition System including:

- (a) Spark plug
- (b) Ignition module/coil

(4) Catalytic Muffler Assembly (if so equipped) including:

- (a) Muffler gasket
- (b) Exhaust manifold

(5) Crankcase Breather Assembly including:

- (a) Breather connection tube.

(6) Miscellaneous items Used in Above Systems including:

- (a) Switches
- (b) Hoses, belts, connectors, and assemblies.

*Covered up to the first required replacement only. See Maintenance Section.

Warranty (Continued)

- Save all instructions

C California Evaporative Emission Control Warranty Statement

YOUR WARRANTY RIGHTS AND OBLIGATIONS

Applies only to Model No. PEA438:

The California Air Resources Board and **METL** are pleased to explain the evaporative emission control system's warranty on your 2010 model year small off-road engine (SORE). In California, new SOREs must be designed, built and equipped to meet the State's stringent anti-smog standards. **METL** must warrant the evaporative emission control system on your SOREs for the period of time listed below provided there has been no abuse, neglect or improper maintenance of your SOREs.

Your evaporative emission control system may include parts such as: carburetors, fuel tanks, fuel lines, fuel caps, valves, canisters, filters, vapor hoses, clamps, connectors, and other associated components.

Manufacturer's Warranty Coverage:

This evaporative emission control system is warranted for two years. If any evaporative emission-related part on your equipment is defective, the part will be repaired or replaced by **METL**.

Owner's Warranty Responsibilities:

- As the SORE owner, you are responsible for performance of the required maintenance listed in your owner's manual. **METL** recommends that you retain all receipts covering maintenance on your SOREs, but **METL** can not deny warranty solely for the lack of receipts.
- As the SORE owner, you should however be aware that **METL** may deny you warranty coverage if your SOREs or a part have failed due to abuse, neglect, or improper maintenance or unapproved modifications.
- You are responsible for presenting your SOREs to distribution center or service center authorized by **METL** as soon as the problem exists. The warranty repairs should be completed in a reasonable amount of time, not to exceed 30 days.

If you have any questions regarding your warranty coverage, you should contact METL customer service:



If you need assistance or have any questions,
CALL TOLL FREE: 1-800-737-2112

Evaporative Emission Warranty Parts List¹:

- (1) Fuel Tank
- (2) Fuel Lines
- (3) Clamps or grommets
- (4) Fuel Cap
- (5) Fuel Tank Bracket

¹As applicable to your product engine emissions certificate

Warranty (Continued)

- Save all instructions

How to Obtain Warranty Service:

You must take your power equipment engine or the product on which it is installed, along with evidence of the date of the sale to the original purchaser, at your expense, to any **METL Authorized Service Center** during its normal business hours. To locate your nearest **METL Authorized Service Center**, call (800) 737-2112. The product owner shall be responsible for any expenses or charges incurred for service calls or transportation of the product or equipment engine to and from the **METL Authorized Service Center**, including any and all damages or losses incurred during such transportation or shipment.

Exclusions:

Failures other than those resulting from defects in material or workmanship are not covered by this Emission Control System Warranty. This Emission Control System Warranty does not extend to emission control systems or parts which are affected or damaged by owner abuse, neglect, improper maintenance, misuse, miss-fueling, improper storage, accident and/or collision, the incorporation of, or any use of, any unapproved, add-on, modified, "graymarket" or counterfeit parts, unsuitable attachments, or the unauthorized alteration of any part. This Emission Control System Warranty does not cover the regular replacement of normal maintenance items made in connection with required maintenance services after the item's first scheduled replacement, as set forth in the Operator's Manual (e.g. spark plugs, air filters, fuel filters, etc...).

Limits of Liability

METL disclaims any responsibility for loss of time or use of the engine, or the equipment in which the engine is installed, transportation, commercial loss, or any other incidental or consequential damage. Any implied warranties are limited to the duration of this written limited warranty. Some states do not allow limitations on how long an implied warranty lasts and/ or do not allow the exclusion or limitation of incidental or consequential damages, so the above exclusions and limitations may not apply to you.

This warranty gives you specific legal rights, and you may also have other rights which vary from state to state.

SYSTEMS COVERED BY THIS WARRANTY:	PARTS DESCRIPTION:
Fuel Metering System	Carburetor assembly (if so equipped) and its internal components; fuel filter (if so equipped), carburetor gaskets, fuel pump (if so equipped)
Air Induction System	Intake pipe/ manifold, air cleaner
Ignition System	Spark plug ¹ , ignition module / coil
Exhaust System	Catalytic muffler assembly (if so equipped), muffler gasket, exhaust manifold
Crankcase Breather Assembly	Breather connection tube
Miscellaneous Parts Used in Above Systems	Hoses, belts, connectors and assemblies
Evaporative Emissions Components ²	Fuel line, fuel line fittings, clamps, fuel tank, carbon canister, canister mounting brackets, carburetor purge port connector
¹ Covered up to the first required replacement only. See the Maintenance Schedule	
² As applicable to your product engine emissions certifications	